

RECORD MACHINE DETAILS

MODEL

SERIAL No.

DATE of PURCHASE

VOLTAGE

PHASE

CYCLES

QUOTE THIS INFORMATION  
WHEN REQUESTING SERVICE  
OR SPARES.

DISTRIBUTOR

**STARTRITE**

**Model 145**

TILT ARBOR SAWBENCHES

**HANDBOOK**

**17E**

**A.L.T. Saws & Spares Ltd**

**Startrite Machine Specialist**

Unit 15, Pier Road Industrial Estate

Gillingham

Kent

ME7 1RZ

Tel/Fax: 01634 850833

[www.altsawsandspares.co.uk](http://www.altsawsandspares.co.uk)

**A.L.T. SAWS & SPARES LTD**

**QUALITY  
TCT CIRCULAR SAW  
BLADES**

**TO SUIT THE T/A145 MODEL**

ORDER LINE- 01634 850833

**A.L.T. SAWS & SPARES LTD**

Unit 15, Pier Road Industrial Estate

Gillingham

Kent

ME7 1RZ

[www.altsawsandspares.com](http://www.altsawsandspares.com)

SPECIFICATIONS :

Model 145	- 9" Standard Tilt Arbor Sawbench
Saw Blade Size	- 230 mm Dia. x 1.6 mm Thick ( x $\frac{5}{8}$ " Hole ) 9" Dia. x .063" Thick ( x $\frac{5}{8}$ " Hole )
Blade Speed	- 2060 m/min., 6750 ft/min.
Max. Rise of Saw 90°/45°	- 80 mm, 3 $\frac{1}{8}$ " / 55 mm, 2 $\frac{1}{8}$ "
Max. Tilt of Saw	- 45°
Motor	- 1 & 3 Phase : 0.9 kW., 1.25 h.p., 2850 r.p.m. 220/240 Volt 3 Phase 50Hz.
Standard Voltages	- 380/440 Volt 3 Phase 50Hz. 220/240 Volt 1 Phase 50Hz.
Gross Weight	- 90 kg., 200 lbs.

WHEN ORDERING PARTS, PLEASE STATE :-

1. Quantity required.
2. Part No. (where applicable) and description.  
Specify power supply for electrical components.
3. Machine Model and Serial No.

NOTE : ILLUSTRATIONS MAY VARY IN DETAIL, ACCORDING TO MODEL.

We reserve the right to change design and specification without notice.  
Startrite Machine Tool Co. Ltd., Waterside Works, Gads Hill,  
Gillingham, Kent, ME7 2SF, England.

ALL DIMENSIONS APPROXIMATE.

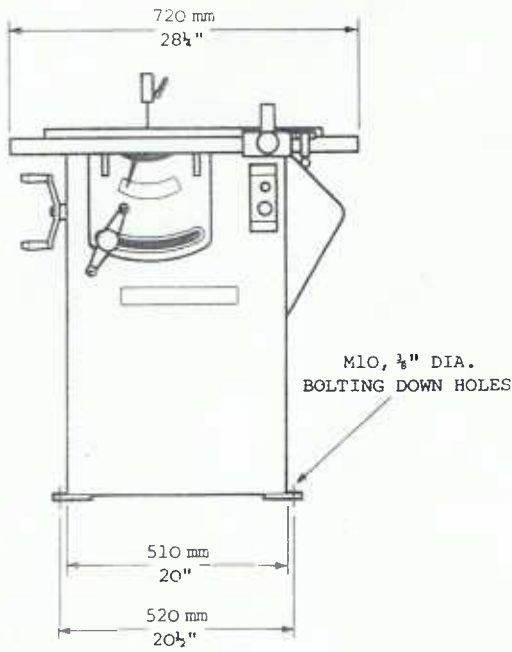

FRONT VIEW

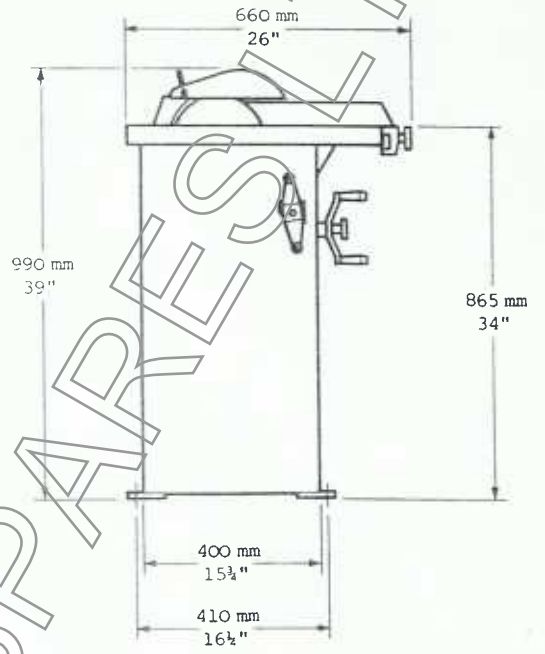

SIDE VIEW

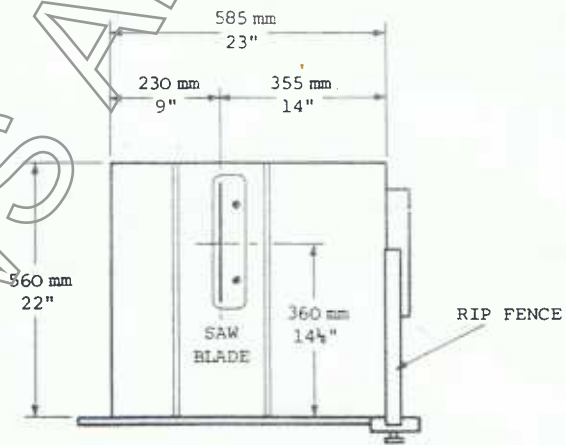

PLAN

FOUNDATION PLAN OF MODEL 145 TILT ARBOR SAWBENCH.

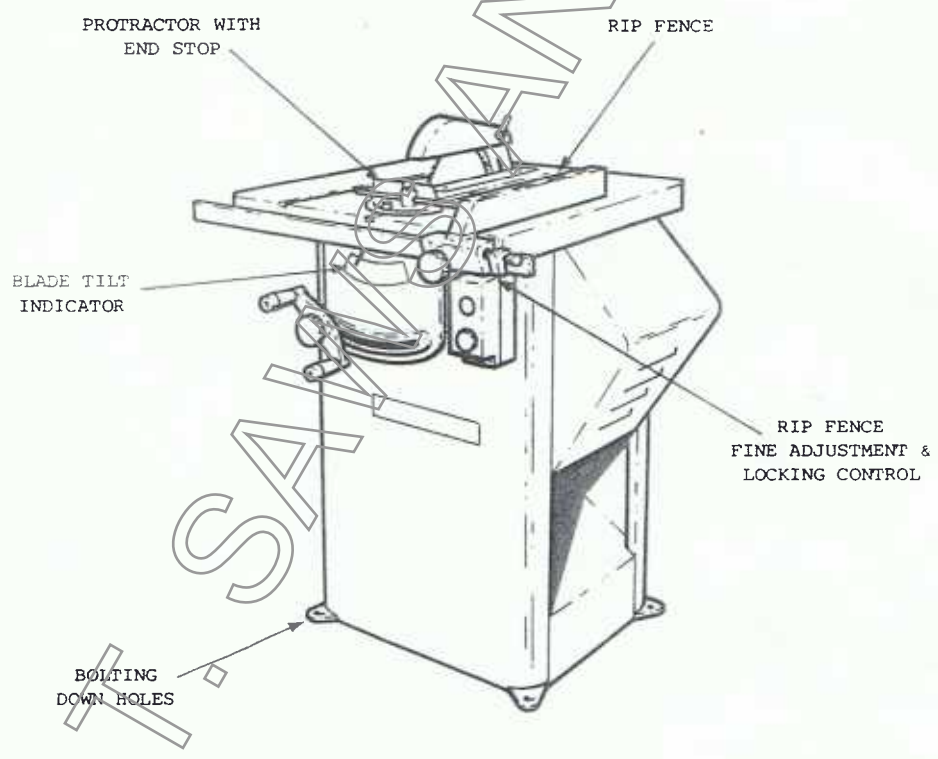
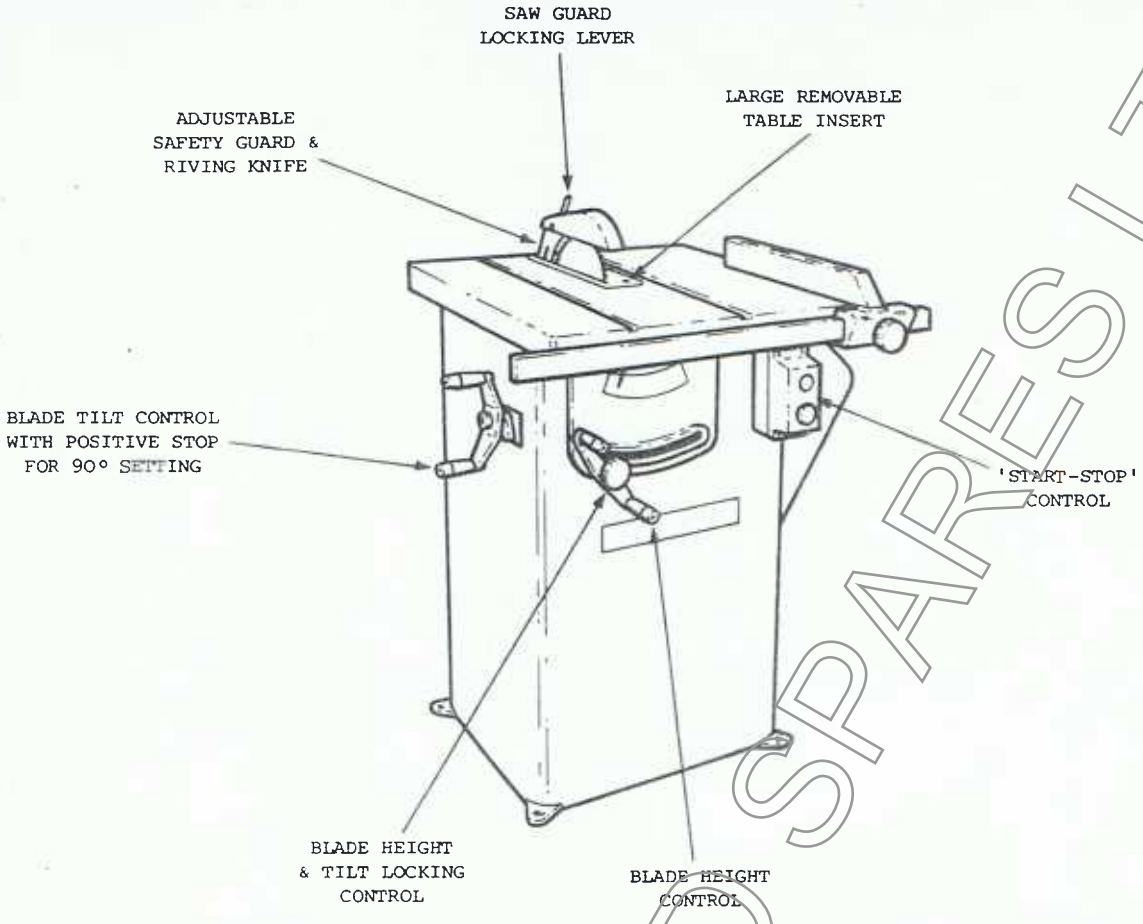

GENERAL LAYOUT OF MODEL 145 TILT ARBOR SAWBENCH

## INSTALLATION.

**WARNING :** Do not move machine by holding rip fence, as this may cause damage to the rack and pinion mechanism (Model 165).

Site the machine with adequate working space around it so as to ensure proper operation without obstruction.

Where possible, choose a position that offers minimum risk of the operators attention being distracted while using the machine. Take advantage of any natural light available and provide adequate artificial lighting over the whole working area.

The floor around the machine must have a level non-slip surface free of any feature which may create a hazard. The cabinet base is provided with four bolting down holes to accept M10 ( $\frac{3}{8}$ " ) diameter bolts (not supplied). Before bolting the machine down, place packing under the feet to ensure that it stands firmly and without wobble.

## CONNECTION TO THE ELECTRICITY SUPPLY.

**IMPORTANT :** Check that the electricity supply is suitable for the machine. At all times, ensure that the machine is isolated from mains supply before making any electrical connections or adjustments.

Fuse and cable recommendations given ( see Chart ) are intended as a general guide only, as local regulations and/or operating conditions may require alternative specifications to be adopted. Motor full load current may vary according to construction. The actual full load current is marked on the motor. Connect the machine to a fused isolator of suitable capacity ( see Chart ) using cable encased in conduit. Temporary connection ( ie. for demonstrations ) may be made with flexible cables, provided that it is protected from accidental damage.

MAINS SUPPLY	FULL LOAD AMPS	MIN WIRE SIZE mm <sup>2</sup>	MAX FUSE AMPS
220/240 VOLT 1 PHASE	7.3	1.0	20
220/240 VOLT 3 PHASE	3.9	1.0	15
380/440 VOLT 3 PHASE	2.25	1.0	15

To connect machine to mains supply, proceed as follows :-

Remove cover of starter ( four screws ).

For single phase supply, connect two supply leads to top terminals ( 1 & 5 ) of contactor ( see Fig.1 ).

For three phase supply, connect three supply leads to top terminals ( 1, 3 & 5 ) of contactor ( see Fig.2 ).

An adequate earth continuity lead ( yellow/green ) must be connected to earth terminal of starter.

**IMPORTANT :** IN ALL CASES THE MACHINE MUST BE EFFECTIVELY EARTHED.

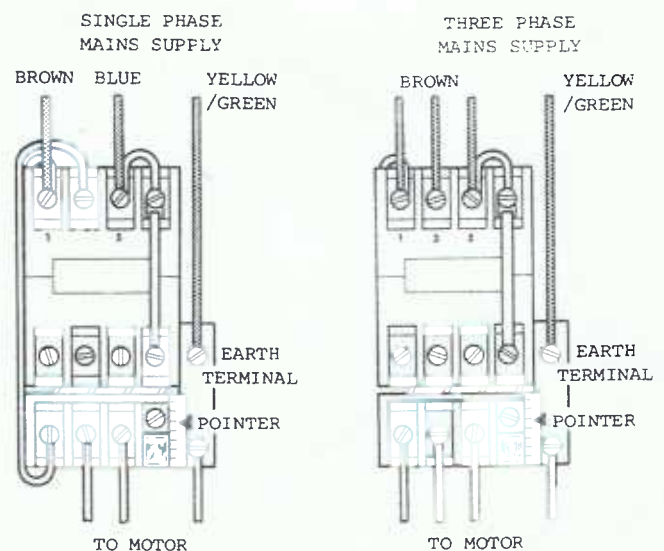

Fig.1.

Fig.2.

## CONNECTION TO THE ELECTRICITY SUPPLY ( CONTINUED ).

The contactor incorporates an overload release and it is essential that it is set correctly in order that the motor is protected against sustained overload. The pointer on the overload unit must be set to indicate the full load amps of the motor.

A three phase motor may run in either direction, therefore, check that leading edge of saw blade passes downward through the table ( see Fig.3 ).

If necessary, interchange any two supply leads to reverse motor rotation.

With all connections made, replace starter cover.

**IMPORTANT :** The service of a competent electrical engineer must be obtained if there is doubt on any point regarding electrical installation.

DIRECTION OF  
SAW BLADE

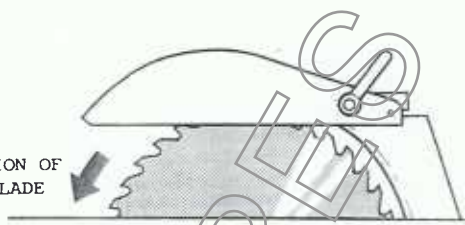

Fig.3.

## OPERATING SAFETY PRECAUTIONS.

BEFORE ATTEMPTING TO OPERATE THE MACHINE, BECOME FAMILIAR WITH THE CONTROLS AND OPERATING INSTRUCTIONS.

NO PERSON SHOULD OPERATE THIS MACHINE WITHOUT SUFFICIENT TRAINING AS TO ITS SAFE AND PROPER OPERATION, OR WITHOUT SUCH SUPERVISION AS MAY BE NECESSARY.

Before starting the machine, check that it is safe to do so. Make sure that all necessary adjustments have been completed and all guards are in position and secure. Never at any time make an adjustment to any part of the machine while the saw blade is in motion.

Never put hands near a moving saw blade. When ripping short lengths or making the last 300mm (12") of a cut use a push stick to feed the work. A push stick should be made from strong straight grained hardwood of rectangular section with one end rounded to form a comfortable grip, and the other end notched to grip the workpiece.

Do not operate the machine with loose cuffs, or with an exposed bandage on the hands. Should it be necessary to wear a tie, prevent the ends from hanging loose. For greater safety wear the type of tie that has a weak elastic neck band or a collar clip.

Always allow the saw blade to cut freely, this is particularly important when feeding warped or irregular timber which may not sit firmly on the table.

Use only a saw blade that is in good condition and suitable for the machine ( see page 7 ) and for the work in hand. A saw blade that is distorted, cracked or has mis-shaped teeth is unsafe to use and should be discarded.

Wet or unseasoned wood may tend to close in and grip the saw blade. This may cause the wood to be flung towards the operator or cause the saw blade to distort due to the heat generated by friction. Caution is also necessary when cross-cutting to an end stop as the workpiece may cross-lock and jam the saw blade.

When feeding small or slender sections, particularly if knots are present, there is a risk of the saw blade snatching the workpiece and ejecting it with violent force. Jigs, push blocks and other devices which allow the operator to control the workpiece with safety should be used under these circumstances.

## OPERATING SAFETY PRECAUTIONS ( CONTINUED ).

Take care not to strike the saw blade or guard by careless handling of the workpiece.

Use extended table supports when handling large sheets ( Model 165 ).

When a wobble saw, or moulding and grooving cutters are used, a Hold Down Unit with some form of tunnel guard should be used, and also a Special Table Insert ( Optional Extras ).

Any person, other than the operator, who is removing material from the machine should stand only at the delivery end of the machine. Under these circumstances the machine should be fitted with the Feed Off Roller Assembly ( Optional Extra ).

Keep the machine table and work area free from tools and off-cuts.

There is considerable risk of accidents through tripping or stumbling due to off-cuts being allowed to accumulate on the floor. A convenient bin should be provided to enable off-cuts to be safely disposed of as fast as they are produced. Vertical stacks of timber should be kept away from the working area to avoid the possibility of long lengths of wood falling across the machine.

Always stop the machine before leaving it unattended. Where there is a risk of personal injury due to unauthorised use, the machine should be made immobilised by means of a Lockable Switch or Tamper Proof Blade Guard Hood ( Optional Extras ) during the operators absence.

Dust Extraction Equipment ( Optional Extra ) should be used, particularly when some hardwoods are being sawn, to reduce pollution of the atmosphere. Some materials, such as asbestos, give off toxic fumes and dust when machined, and in such cases it is necessary to seek expert advice as to the method of dust extraction.

## SETTING UP THE MACHINE.

Set the saw blade tilt upright (  $0^\circ$  on tilt scale ) and raise the saw blade to its maximum height. Remove saw guard, table insert and saw blade. Clean spindle nose and thread with a suitable brush and apply a few drops of very thin oil. Place clamping washer ( Item 85 - see Parts List ) on spindle with dished side towards spindle nose giving maximum clamping area. Place suitable saw blade on spindle, ensuring that the central portion is free from dust and dirt. Place second clamping washer on spindle with dished side facing saw blade. Screw on spindle nut ( Item 86 ) and clamp saw blade in position. To prevent spindle turning whilst this is being done, the tommy bar ( supplied ) should be inserted through the hole in the table so as to engage with the opposite end of the spindle. Undue force should not be used when tightening spindle nut.

The minimum size rip or cross-cut saw blade to be used is :-

137 mm ( 5.4" ) diameter

The plate thickness of a parallel plate saw blade should be less than the thickness of the riving knife.

The riving knife should be set so that it is not more than 12 mm (  $\frac{1}{2}$ " ) from the blade teeth at table level ( see Fig.4 ). The saw blade should not be more than 25 mm ( 1" ) higher than the riving knife.

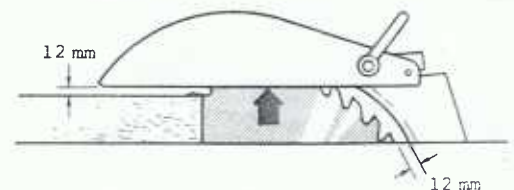

Fig.4.



## SETTING UP THE MACHINE ( CONTINUED ).

Replace table insert and saw guard. At all times the guard should be set to cover the gullets of the teeth at some point ( see Figs.4 & 5 ).

Place workpiece on table and set saw blade to required height and tilt. The front of the guard should not be more than 12 mm (  $\frac{1}{2}$ " ) above the top of the workpiece ( see Fig.4 ). Position the rip fence as required and lock in place.

The protractor ( standard equipment ) is used to guide the workpiece whilst cross-cutting and permits the cutting of compound mitres. The scale, marked in degrees provides a useful guide for setting the required angle, but a test piece should be carefully checked for accuracy before proceeding further.

Feed Off Roller Assembly and set of Feed & Run Off Rollers ( Model 165 ) are available ( Optional Extras ), and these will considerably assist in the handling of large sheets.

MODEL 165 : To cut large panels it will be necessary to set up the table extensions ( standard equipment ). These may be fitted all to one side of the machine, using support legs ( Optional Extra ), or a pair on each side according to the nature of the job. Before fitting the extension bars, ensure that the screw threads and locating faces are clean. A few drops of light oil on these faces will prove useful. The fine adjustment control on the rip fence must be pulled outwards so as to disengage the pinion before the fence can be moved onto the extension bars. It should be noted that whilst a long fence is useful in guiding sheets, for rip sawing, the fence should finish level with the commencement of the cut. Therefore, a wooden facing is fitted to the fence to prevent the timber jamming should there be a tendency for it to splay out. A steel face plate is available as an Optional Extra.

## HOLD DOWN UNIT ( OPTIONAL EXTRA ).

The hold down unit is a device having leaf springs which hold the workpiece against the rip fence and down onto the table ( see Fig.6 ). When fitted, the bearing portion of the springs are more or less over the saw centre.

MODEL 145 : The mounting bracket must be removed ( 1 set screw ), and the support pillar can be located in the hole at the rear of the rip fence ( SP263 ) and secured by means of the set screw from the mounting bracket.

MODEL 165 : The unit can be bolted directly to the top of the rip fence ( SP191 ) as shown in Fig.6.

The unit complies with the requirements of the Woodworking Machinery Regulations 1974 ( U.K. ) when fitted with pressure pads that form an effective tunnel type guard around a wobble saw or moulding block. Suitable pressure pads can be easily made and fitted by the user to suit the nature of the work to be carried out.

The unit should be adjusted so that the leaf springs bear down on the top and side of the workpiece. Excessive spring pressure should be avoided as this makes it difficult to maintain a smooth and even feed.

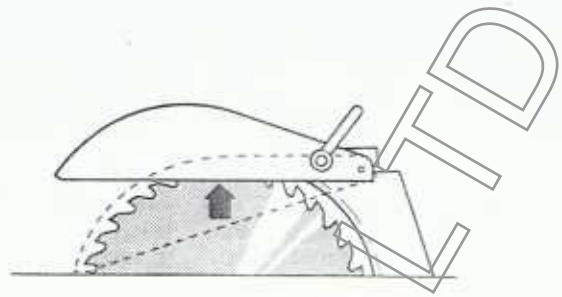

Fig.5.

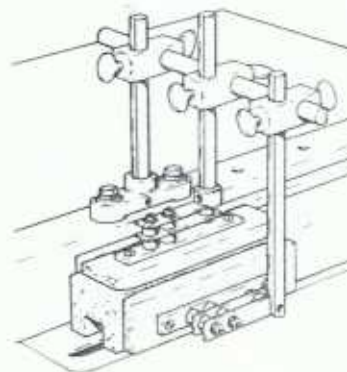

Fig.6.

### WOBBLE SAW ( OPTIONAL EXTRA ).

The wobble saw comprises of a robust saw blade, complete with a set of tapered washers ( see page 24 ). By adjusting the relative position of the washers the saw blade may be made to 'wobble', and thus cut a groove ( see Fig.7 ). Both blade clamping washers ( Item 85 ) must be removed from the saw spindle before the wobble saw assembly can be screwed on. To adjust the amount of wobble ( and thus the width of the groove ), slacken off the slotted locking ring and whilst holding the saw hub stationary, rotate the saw blade together with the two immediate washers, and tighten locking ring.

The wobble saw should be used in conjunction with the Hold Down Unit ( see page 8 ) and the Special Table Insert ( Optional Extra ).

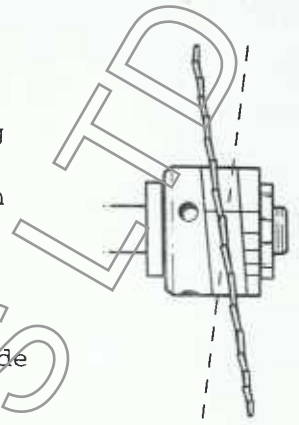

Fig.7.

### MOULDING & GROOVING BLOCK ( OPTIONAL EXTRA ).

The moulding and grooving block consists of a circular steel block with provision for holding a pair of specially shaped cutters ( see Fig.8 ). Various patterns are available for moulding, trenching, rebating, tonguing and grooving ( see page 24 ). To set up the block place it on the saw spindle with one of the clamping washers ( Item 85 ) behind it and the locking wedges leading. The second clamping washer is omitted and the block is secured to the spindle by a standard nut which seats directly in the centre recess.

Position one cutter in the block with its clearance angle behind the cutting edge. Raise saw spindle so that when the block is rotated, the edge of the cutter will just touch a straight edge laid across the table insert opening. Without moving the saw arm, position the second cutter in a like manner, ensuring that the two cutters are in line. Check locking screws for tightness before using the block.

All cutters are supplied in matched pairs for both form and weight. It is most important, therefore, that both cutters are re-sharpened in an identical manner as even a small difference in weight will set up considerable vibration when the block is in use. In view of this, it is recommended that the job of re-sharpening moulding cutters be entrusted to specialists.

The moulding and grooving block should be used in conjunction with the Hold Down Unit ( see page 8 ) and the Special Table Insert ( Optional Extra ).

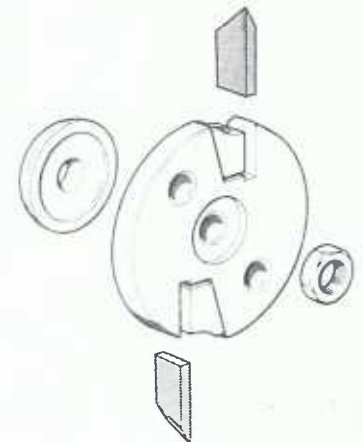

Fig.8.

### RIP & CROSS-CUT SAW BLADES.

NOTE : The most important part of the machine is the saw blade itself. It is unsafe to use a saw blade that is in bad condition or of the wrong type, and is bound to result in wasted time and material.

A saw blade should be re-sharpened as soon as the teeth lose their keen points, and persistent attempts to force timber through a blunt saw blade will cause the blade to distort through overheating, and may damage the motor and bearings. Such distortion may become permanent and in this event, the saw blade is unfit for further use and should be discarded.

## RIP & CROSS-CUT SAW BLADES ( CONTINUED ).

If it is not possible to re-sharpen the saw blade on the premises where it is being used, alternative saw blades should be at hand to prevent the machine from standing idle.

The rip saw blade, as its name implies, is used for rip sawing timber lengthwise, ie. with the grain. It will of course, cut across the grain, but the finish tends to be ragged. The teeth have a fairly coarse pitch and positive hook. The amount of hook, or front rake is approximately  $25^\circ$  for soft woods, decreasing to  $15^\circ$  or even  $10^\circ$  for hard woods. The hook of the blade is defined as the angle subtended by the front edge of the tooth to a radial line touching its tip. Whilst maximum amount of hook is desirable for fast cutting, there is a tendency for the teeth to 'hammer' in hard wood and in knots.

The clearance angle is the back slope of the tooth, and is measured to a line drawn tangential from the tip. This angle is usually around  $15^\circ$  but sometimes, however, it may be increased to  $25^\circ$  for very soft woods. Although the maximum clearance angle and front rake make for easy penetration into soft woods, they tend at the same time to weaken the points of the teeth, and teeth weakened in this fashion will be found to blunt very easily.

The rip saw blades as received from the manufacturer will have the teeth shaped to meet average conditions, and this shape should not drastically be modified without good reason.

Spring set saws have the clearance angle filed at an angle to the axis of the saw blade and this is called top bevel. Soft woods require a top bevel of  $15^\circ$ , this being reduced to around  $5^\circ$  for very hard woods. The top bevel has the effect of giving a shearing action to the tooth and tends to produce a cleaner cut. It must, of course, be noted that the top bevel slopes outwards to the tip of the tooth according to which way the hook is set, thus the top bevel will run the same way on alternate teeth only. Front bevel to the teeth should be kept to the minimum and should certainly not exceed  $5^\circ$  for hard woods.

Cross-cut saw blades differ mainly from rip saw blades by their negative hook of up to  $30^\circ$ . They are intended for sawing across the grain and also for cutting plywood, blockboard and other similar materials. They are usually spring set with a clearance angle of up to  $60^\circ$ . Top and front bevels are usually around  $15^\circ$ , but less will be required on very hard woods.

Only the periphery of the saw blade should be in contact with the workpiece and this condition is met on rip saw blades by spring setting, or swaging the tips of the teeth so that they protrude beyond the face of the saw blade. With spring setting the tips of the teeth are bent outwards, either by means of a saw set hammer blow upon a special anvil, adjacent teeth being set in the opposite direction. The set should be made tangential and from a position not more than one third of the way down from the tip of the tooth. It should be remembered that a saw blade with one or two over-set teeth will produce ugly score marks on every piece of wood it cuts. The amount of set required for general purposes is approximately 0.25 mm (.010") each side of the saw blade, but the golden

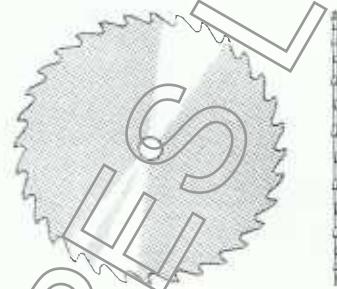

RIP TOOTH  
SAW BLADE

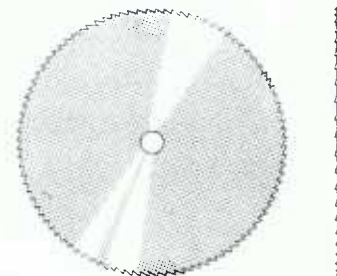

CROSS-CUT  
SAW BLADE

## RIP & CROSS-CUT SAW BLADES ( CONTINUED ).

rule is to apply the least amount which prevents the saw blade from binding in the cut. Some woods by their nature tend to be woolly or exude resin, and extra care must be allowed in these cases, but it must be borne in mind that the wider the kerf, the more power required to drive the saw blade. To avoid an accumulation of resin building up in the saw blade, the blade should be frequently wiped clean with a rag soaked in petrol or other suitable solvents.

NOTE : It is incorrect to set the teeth after the sharpening operation.

## SHARPENING SAW BLADES.

General purpose rip and cross-cut saw blades are usually made from carbon steel and these may be easily re-sharpened by hand. Before sharpening, ensure that the saw blade runs true by stoning the teeth. This is done by first lowering the saw blade into the machine until it is below the table. Place a coarse emery stone over the table slot and very gently raise the saw blade until the teeth just make contact with the emery stone. Remove emery stone, and start the machine. Slide the emery stone over the tips of the saw blade until a witness mark appears on every tooth.

Remove the saw blade from the machine and clamp in a suitable vice. File the top bevel of each tooth in the direction of the set until the witness mark is just removed.

It may be necessary to dress the front bevel, but take care not to remove more of the tooth profile than is required and to dress all teeth equally.

WARNING : Take extra care when stoning saw blades. It is advisable to wear eye protection and use an emery stone large enough to be held down firmly on the table by both hands.

## HOLLOW GROUND SAW BLADES.

Hollow ground saw blades have their faces relieved by grinding to produce the necessary working clearance, but the shape of the tooth may vary considerably according to the purpose for which it is intended.

One type has teeth of the novelty combination pattern and is called a mitre or planer blade. This saw blade is used mainly for cross-cutting, or cutting thin sections and leaves a surface equal to a planed finish. It should be noted, however, that the planer blade is not intended as a substitute for the planing machine.

Hollow ground saw blades are also available for cutting a wide range of light alloys and plastics. Quite often the correct requirements for sawing these materials may only be determined by experiment, but the following notes should prove a useful guide.

For maximum cutting speed, saw blades of the greatest possible pitch should be used, but it must be ensured that there are at least two teeth in engagement. On harder materials it will be necessary to have more teeth in engagement in order to avoid the blade chattering in the cut. A fine pitch saw blade is essential for cutting very thin sections, and the height of the saw blade should be reduced to avoid chipping the underside of the material. Heavier sections of some plastic materials will cut much more easily if the saw blade is lubricated with soap, or soapy water.

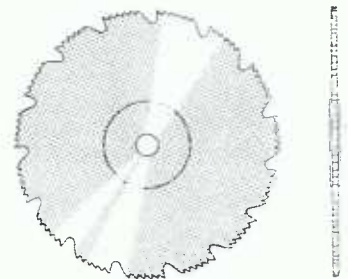

HOLLOW GROUND  
MITRE SAW BLADE

## HOLLOW GROUND SAW BLADES ( CONTINUED ).

Aluminium, zinc and lead based alloys may be sawn in thin sections and a few drops of paraffin or soluble cutting oil makes for easier cutting and a better finish.

Due to the small working clearance of hollow ground saw blades there is a marked tendency for them to overheat once the teeth have lost their fine edge, and it is important, therefore, that these blades are frequently re-sharpened.

Saw blades with tungsten carbide stellite tipped teeth are available, and for cutting hard or abrasive materials it will be found that their high initial cost is well justified.

When saw blades of other than standard gauge thickness are used it may be necessary to fit a special riving knife of suitable thickness.

It must be borne in mind that the machine is designed primarily for cutting timber, and consequently its spindle speed is usually too great for sawing hard or abrasive materials.

A smaller diameter saw blade will give a lower peripheral speed. In addition, a smaller diameter saw blade is much stiffer due to its reduced diameter, and this is an important factor in preventing blade wander.

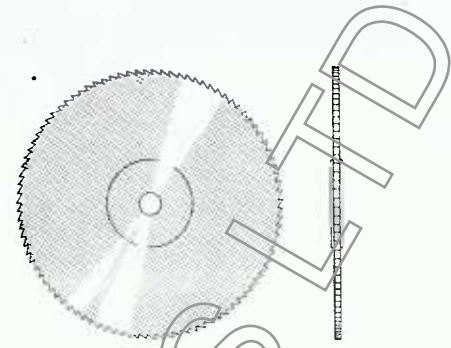

HOLLOW GROUND  
CROSS-CUT SAW BLADE

## MAINTENANCE.

The motor and saw spindle are mounted on sealed-for-life bearings and do not require further lubrication.

Periodically clean the spindle nose and thread with a suitable brush to remove any gummy deposits. Blow out the interior of the machine to clear all moving parts of dirt and dust deposits. Apply a few drops of very thin oil to spindle nose and all working surfaces.

Check the belt tension after the first five hours running, and weekly thereafter. The belt tension is adjusted by slackening off 3 screws ( Item 71 ) and rotating motor flange ( Item 93 ) as required. A good guide as to the correct belt tension is that it should be possible to give the vee-belt a quarter twist midway between pulleys using thumb and forefinger only. The vee-belts are fitted as a matched pair and should only one belt fail, it is necessary to replace both belts ( Part No.M22 ).

**CAUTION : DO NOT OVER TENSION VEE-BELTS,** as this may damage both the belts and the bearings.

APRON - BLADE HEIGHT & TILT MECHANISM - ASSEMBLY No.SP177A

ITEM	PART NUMBER AND DESCRIPTION	No.OFF
1	1736 Apron	1
2	1788 Shaft	1
3	Key	2
4	Hex. Hd. Screw	1
5	Hex. Nut	1
6	2069 Tilt Shaft Bracket	1
7	2072 Compression Spring	1
8	Circlip External	1
9	2070 Positive Stop Pin	1
10	Compo Bush	4
11	Soc. Set Screw	4
12	Handle	4
13	Shoulder Screw	4
14	Std. Washer	2
15	Hex. Locknut	3
16	3340A Handle	1
17	2071 Positive Stop Collar	1
18	1798 Special Washer	2
19	Hex. Hd. Screw	9
20	Std. Washer	10
21	1795 Special Washer	4
22	Needle Thrust Race	2
23	SP212 Universal Joint	2
24	1790 Shaft	1
25	2013 Feed Screw	1
26	1814 Trunnion Nut	1
27	5634 Special Nut	1
28	Circlip External	2
29	Mills Pin	1
30	Mills Pin	4
31	1791 Feed Screw	1
32	5735 Trunnion Nut	1
33	Hex. Nut	4
34	1812 Pivot Pin	1
35	5651 Deflector Plate	1
36	1738 Tilting Arm	1
37	1777 Internal Shoe	2
38	Soc. Hd. Cap Screw	2
39	1737 Segment	1
40	Std. Dowel	2
41	Spring Dowel	2
42	Hex. Hd. Screw	1
43	Std. Washer	1
44	Rd. Hd. Screw Recessed	2
45	Soc. Hd. Cap Screw	4
46	Self Locking Nut	4
47	Std. Washer	4
48	3336 Tilt Scale	1
49	3338 Pointer	1
50	1793 Pointer Support	1
51	1776 External Shoe	1
52	1794 Eccentric Screw	1

( CONTINUED )

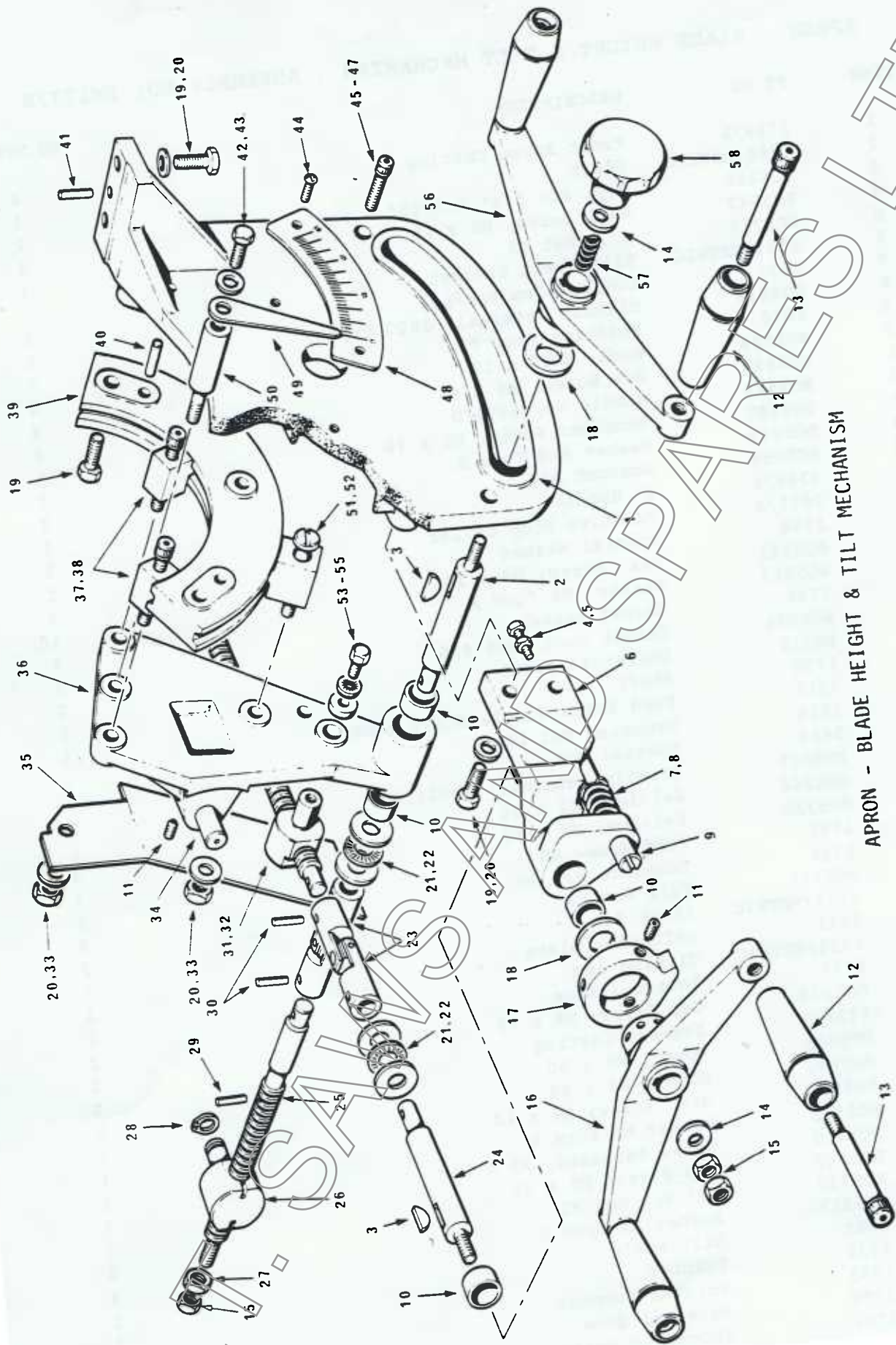

APRON - BLADE HEIGHT & TILT MECHANISM

APRON - ASSEMBLY No.SP177A - CONTINUED

ITEM	PART NUMBER AND DESCRIPTION	No. OFF
53	Hex. Hd. Screw	1
54	Shakeproof Washer	1
55	5736 Washer	1
56	3340 Handle	1
57	1499 Compression Spring	1
58	5130 Handknob	1

SAW SPINDLE ARM & MOTOR PLATFORM - ASSEMBLY No.SP269

ITEM	PART NUMBER AND DESCRIPTION	No. OFF
70	SM229 Motor Platform	1
71	Soc. Hd. Cap Screw	3
72	Soc. Set Screw	1
73	1938 Pulley	2
74	1150 Key	1
75	Vee-Belt	2
76	Hex. Hd. Screw	3
77	Self Locking Nut	1
78	Key	1
79	1935 Saw Spindle	1
80	2200 Saw Arm	1
81	Ball Bearing	2
82	1937 Spacer Tube	1
83	Circlip Internal	3
84	5109 Bush	1
85	2199 Riving Knife Arm	1
86	1936 Clamping Washer	2
87	1190 Spindle Nut	1
88	Circlip External	2
89	Compo Bush	2
90	2151 Pivot Pin	2
91	Hex. Nut	2
92	2202 Tie Bar	1
93	1775 Motor Flange	1
94	1799 Motor Flange Clamp	3
95	Hex. Hd. Screw	3
96	2147 Pivot Block	1

17E  
18E



SAW SPINDLE ARM & MOTOR PLATFORM

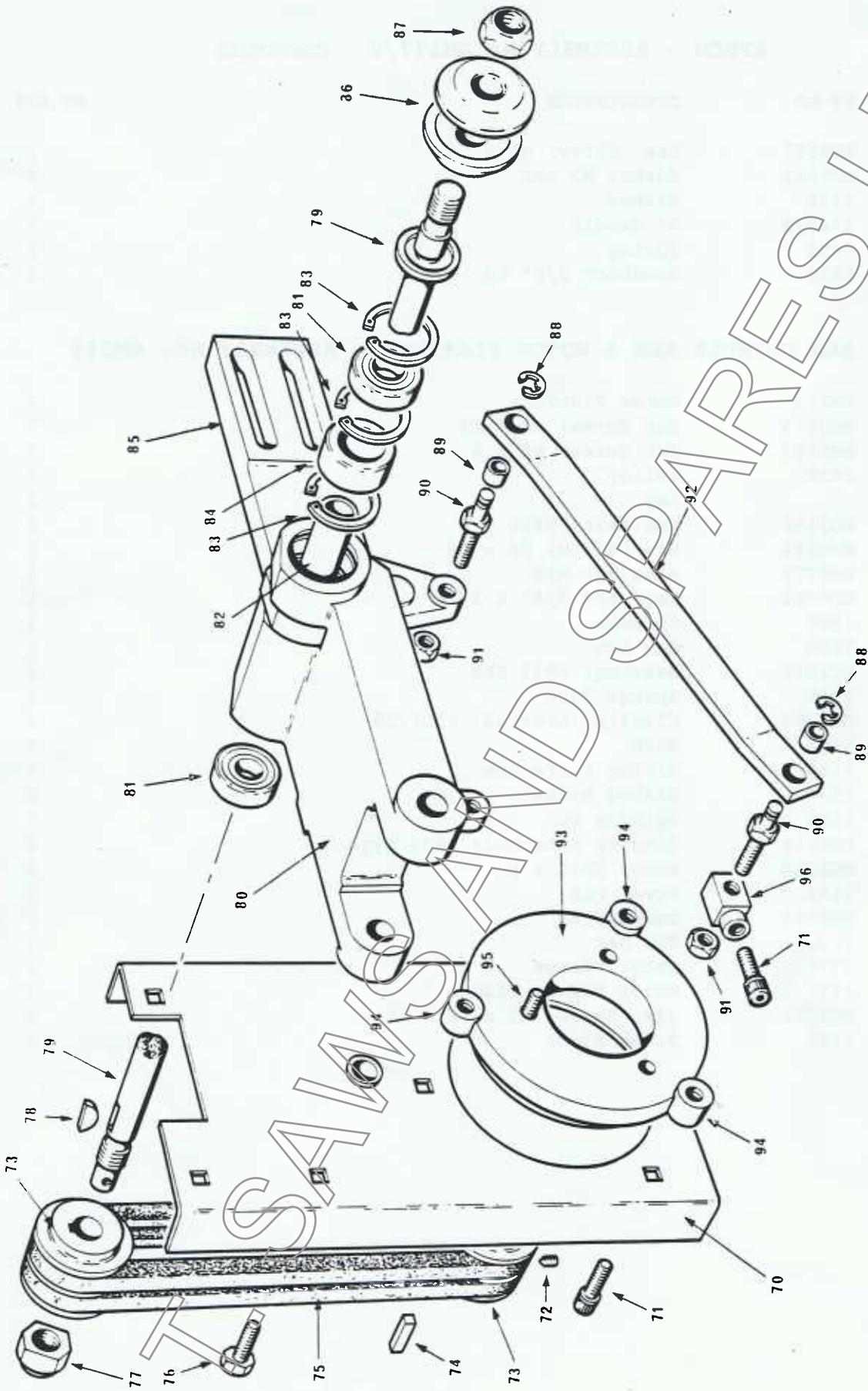

RIP FENCE - ASSEMBLY No.SP263

ITEM	PART NUMBER AND DESCRIPTION	No. OFF
110	2167 Fence Body	1
111	Hex. Nut	1
112	2178 Fine Adjustment Bracket	1
113	2177 Fine Adjustment Thumb Nut	1
114	C'sk. Hd. Screw Slotted	1
115	Thumb Screw	1
116	Handknob	1
117	Hex. Nut	1
118	125 Stud	1
119	Soc. Hd. Cap Screw	1
120	2176 Fence Bracket	1
121	1836 Pointer	1
122	Soc. Set Screw	1

PROTRACTOR - ASSEMBLY No.SP153A

ITEM	PART NUMBER AND DESCRIPTION	No. OFF
150	Protractor	1
151	Thumb Screw	1
152	212 End Stop	1
153	126 Thumb Screw	1
154	2145 Tenon Strip	1

A.L.T. SAINS AND SPARES LTD

ALTS LTD

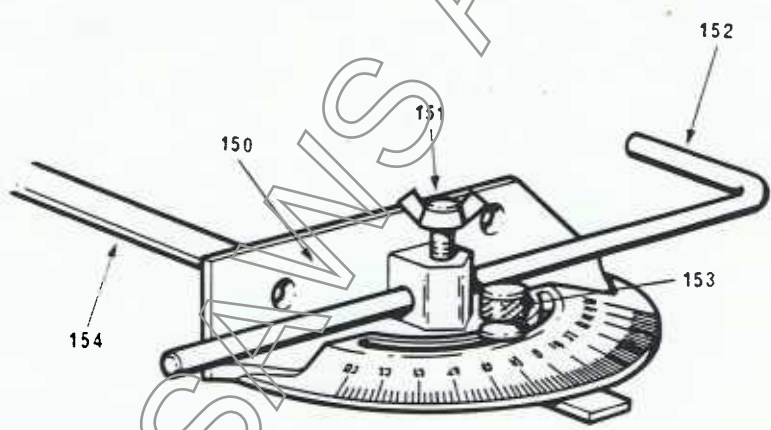
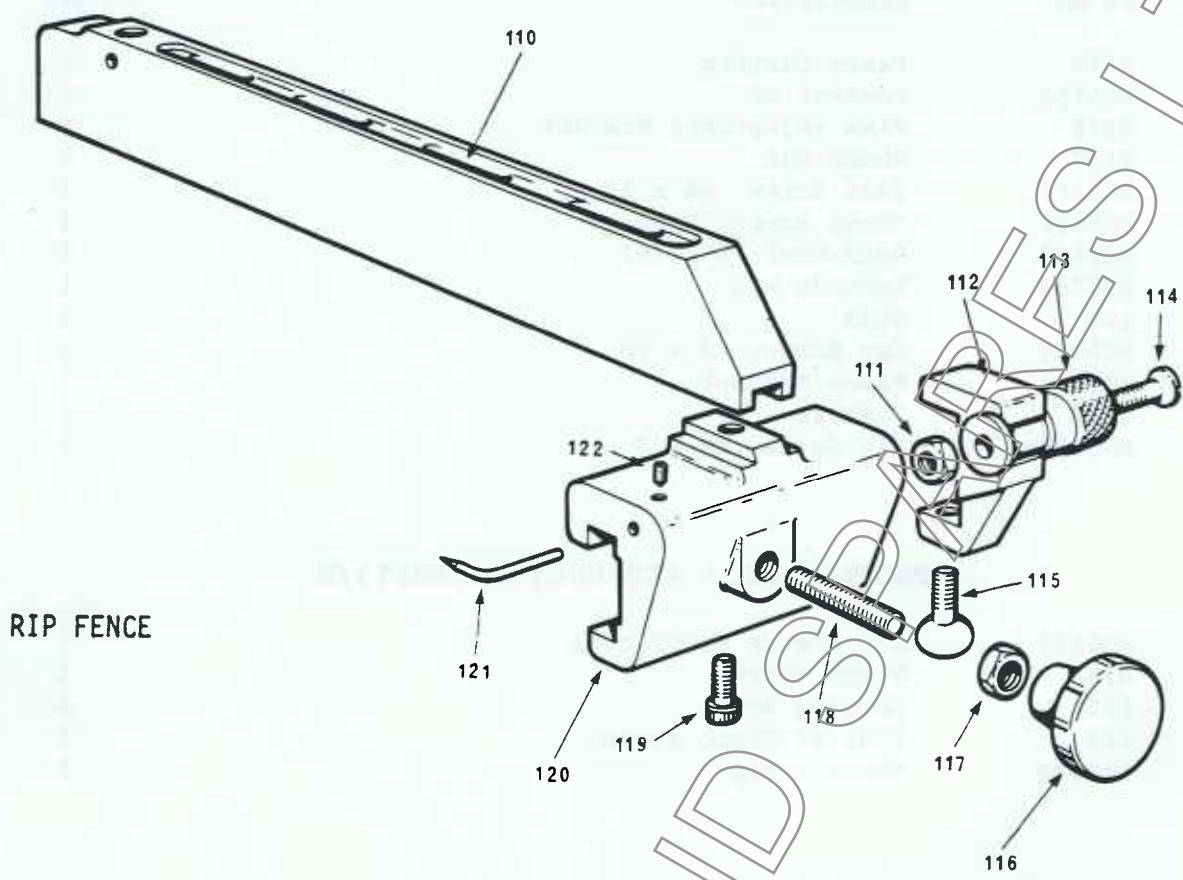

ALTS

SAW GUARD & RIVING KNIFE - ASSEMBLY No.SM973

ITEM	PART NUMBER AND DESCRIPTION	No. OFF
190	5415 Guard	1
191	Hex. Hd. Screw	2
192	Std. Washer	1
193	Mills Pin	1
194	4943 Locking Lever	1
195	5416 Riving Knife	1
196	4941 Washer	1
197	4940 Stud	2
198	Hex. Nut	4
199	4942 Spacer	2
200	5417 Spacer	2
201	5468 Spacer	1
202	Hex. Hd. Screw	1
203	4938 Clamp	2
204	1945 Table Insert	1
205	Soc. Set Screw	4
206	Hex. Nut	4
207	Rip Saw Blade	1

TABLE ASSEMBLY

ITEM	PART NUMBER AND DESCRIPTION	No. OFF
220	1911 Table	1
221	2144 Fence Bar Seating Washer	3
222	Soc. Hd. Cap Screw	3
223	2179/M Scale - Metric	1
	2179/C Scale - Imperial	1
224	2143 Fence Bar	1

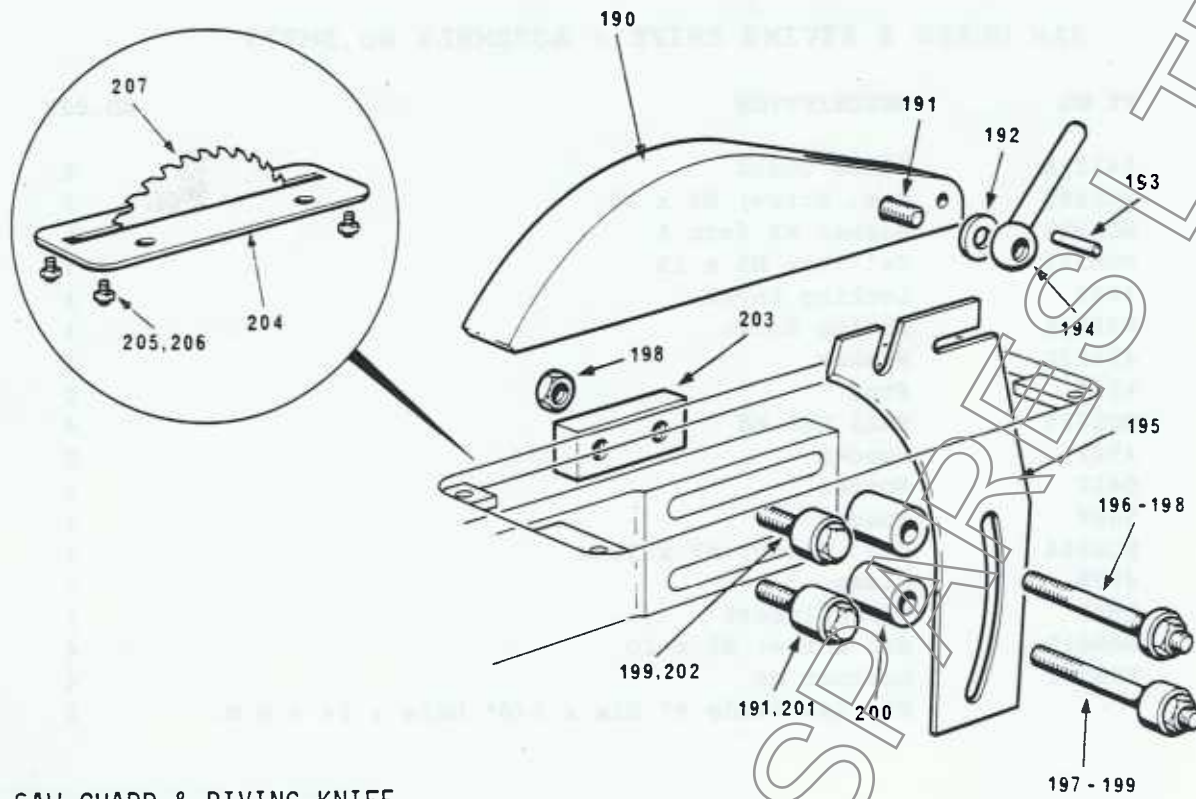

SAW GUARD & RIVING KNIFE

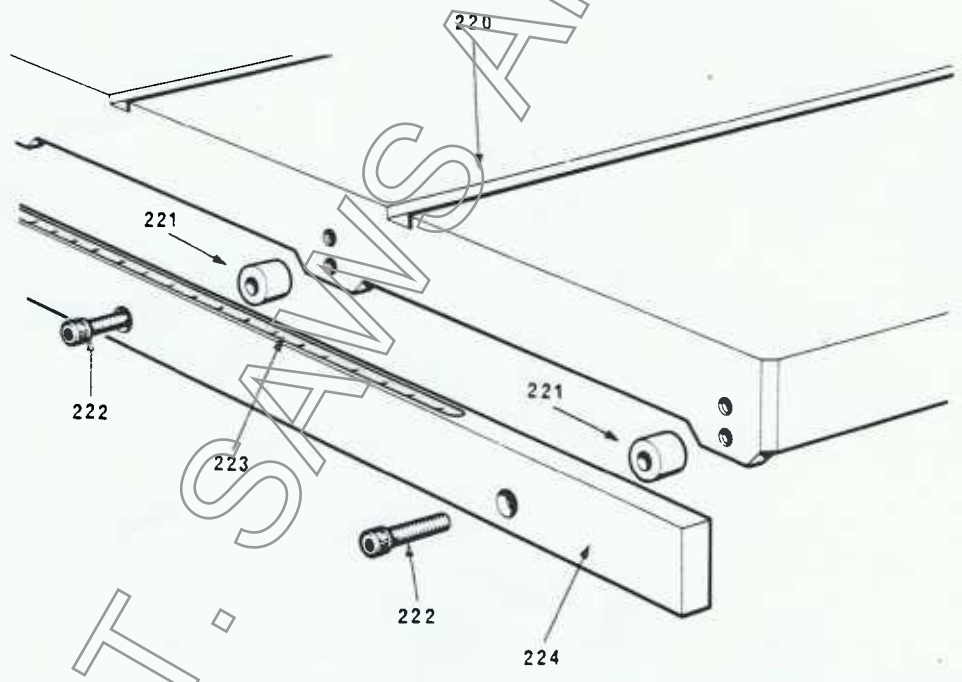

TABLE ASSEMBLY

OPTIONAL EXTRAS & ACCESSORIES

ITEM	PART NUMBER AND DESCRIPTION
250	'Cyclair' Extractor Unit - 1 Phase 'Cyclair' Extractor Unit - 3 Phase
251	SM1054 Lower Extractor Coupling Kit, enables Extractor Unit to be coupled directly to sawbench (rubber connecting sleeve and elbow not shown)
252	SM898 Tamper Proof Blade Guard Hood, complete with mounting bracket, lock and keys.
253	SM926 Feed Off Roller Assembly. Complies with the requirements of the Woodworking Machinery Regulations 1974 (U.K.), and gives an additional working area of 1040mm (41") wide x 1145mm (45") long.

NOT ILLUSTRATED :

SM881/1 Key Operated Switch  
SM1066 Fused Isolator  
SM1067 Trailing Foot Switch  
SM1068 Electrical Interlock  
SM1069 Non-Fused Isolator

A.L.T. SAWS AND SPARES LTD

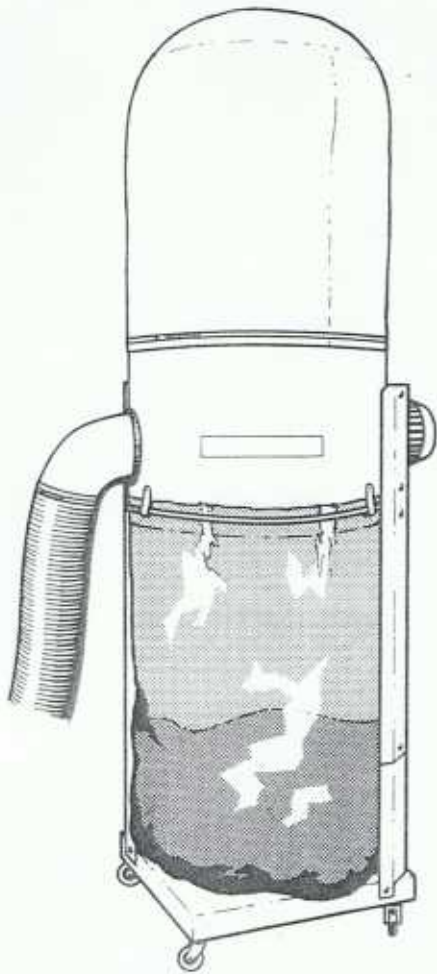

250

'CYCLAIR'  
EXTRACTOR UNIT

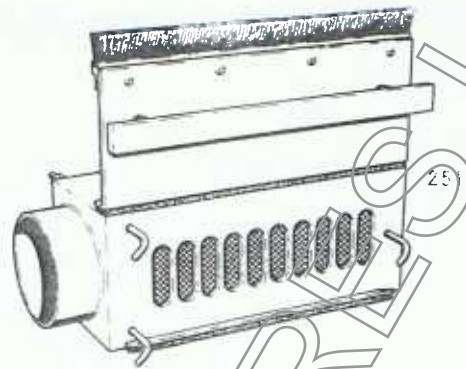

LOWER EXTRACTOR  
COUPLING KIT

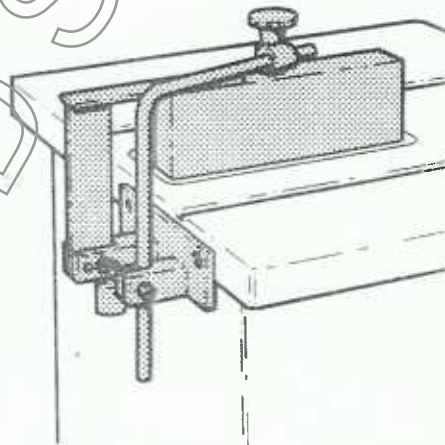

TAMPER PROOF  
BLADE GUARD HOOD

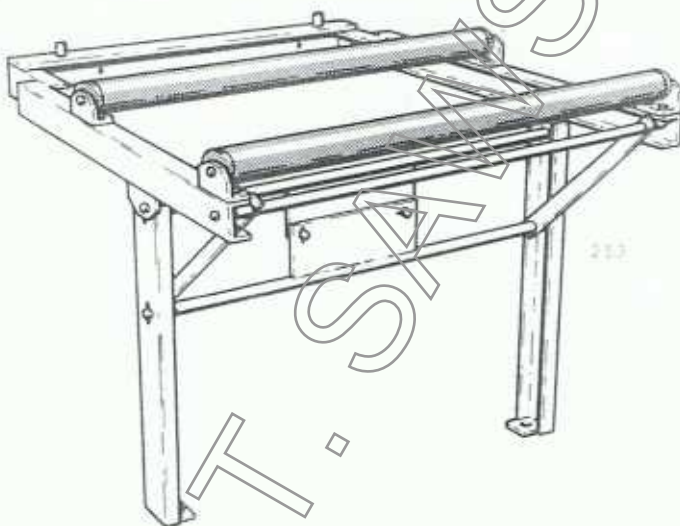

252

FEED OFF ROLLER ASSEMBLY

## OPTIONAL EXTRAS & ACCESSORIES

ITEM	PART NUMBER AND DESCRIPTION
260	SM833 Hold Down Unit. Complies with the requirements of the Woodworking Machinery Regulations 1974 (U.K.).
261	Safety Pattern Moulding & Grooving Block 90mm (3½") dia.
262	Moulding Cutters for above. Supplied in pairs, quote Pattern No. when ordering.
263	SP254 Wobble Saw ¼" - ⅝" capacity, complete with screwed and graduated collar, 'C' spanner and tommy bar.
264	1946 Special Table Insert (must be used with Wobble Saw and Moulding Block).

### SAW BLADES :

265	8" & 9" Dia Rip or Cross-Cut saw blades for cutting wood (16 S.W.G.)
	8" & 9" Dia Novelty Combination saw blades for cutting wood.
	8" & 9" Dia Hollow Ground Cross-Cut and Mitre saw blades for accurate clean end grain cutting.
	8" Dia Hollow Ground Alloy Steel saw blades for cutting plastic (14 S.W.G.) - 5, 8 or 10 T.P.I.
	8" Dia Hollow Ground Carbon Steel saw blades for cutting thin plastic sheet (14 S.W.G.) - 16 T.P.I.
	8" Dia Hollow Ground High Speed Steel saw blades for cutting plastics and light alloys (14 S.W.G.) - ⅜", ¼" or ⅜" pitch.
	8" & 9" Dia Carbide Tipped Saws for cutting industrial plastics, abrasive hardwoods, hardboard, chipboard, non-ferrous metals graphite etc. -
	8" Dia - Available in 16, 20, 32, 36 & 60 teeth
	9" Dia - Available in 24, 36, 40, 48 & 60 teeth



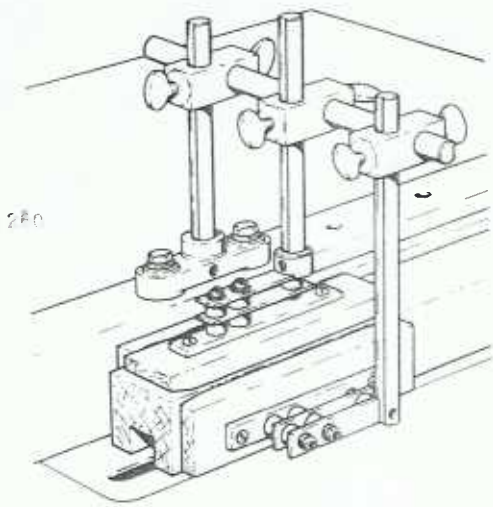

HOLD DOWN UNIT

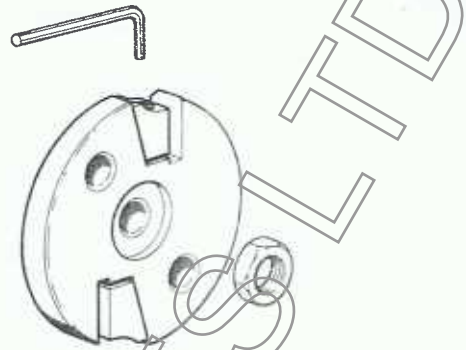

MOULDING & GROOVING BLOCK

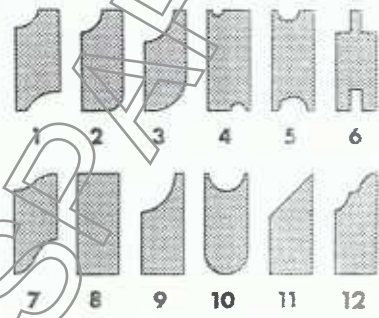

MOULDING CUTTERS

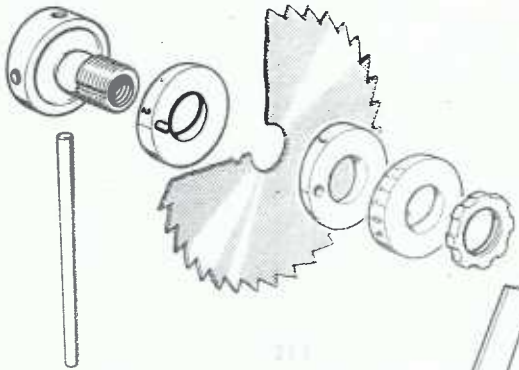

WOBBLE SAW



SPECIAL TABLE INSERT

SAW BLADES

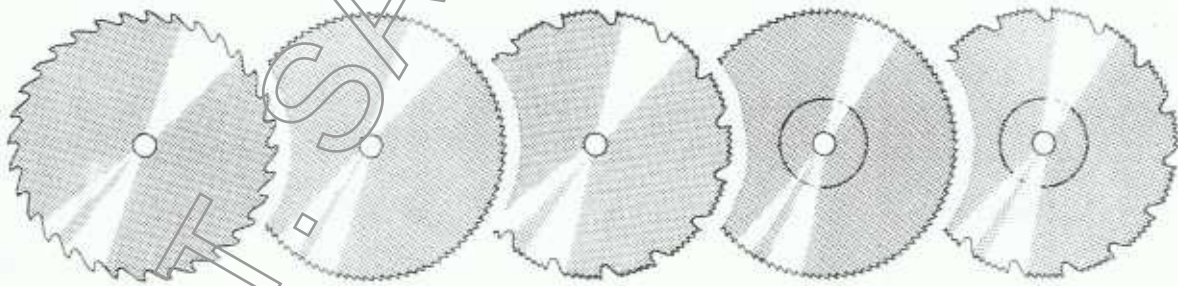

RIP TOOTH

CROSS-CUT TOOTH

NOVELTY COMBINATION TOOTH

HOLLOW GROUND CROSS-CUT

HOLLOW GROUND MITRE